

NL	Gebruiksaanwijzing	p. 2
FR	Mode d'emploi	p. 12
DE	Bedienungsanleitung	S. 22
EN	User manual	p. 32

Novy Mini Pure'line

810 - 811 - 816

820 - 821 - 826



810 110541 GA1

NOVY

NOVY

Novy Mini Pure'line

810 - 811 - 816

820 - 821 - 826

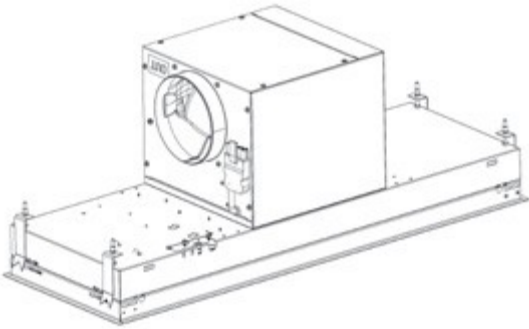

CONTENT

1 INSTRUCTIONS FOR SAFETY AND USE 33

2 CONTROLS AND FUNCTIONS 35

2.1 Operating the device	35
2.2 Turning the extraction on and off	35
2.3 Lighting	36
2.4 Programming recirculation (optional)	36
2.5 Remote control	36
2.6 InTouch	37

3 CLEANING AND MAINTENANCE 37

3.1 General maintenance	38
3.2 Removing the bottom panel	38
3.3 Grease filter	38
3.4 Monoblock recirculation filter (optional)	39
3.5 Led lighting	39
3.6 Change the batteries	40
3.7 Faults	40

4 QUICKGUIDE 41



4.1 Settings	41
4.2 Indications	41

1 INSTRUCTIONS FOR SAFETY AND USE

Further information on Novy products, accessories and services may be found on the internet: www.novy.com

These are the directions for use for the appliance as shown on the front. The installation instructions are in a separate booklet supplied with the appliance.

These directions for use make use of a number of symbols. The meanings of the symbols are shown below.

Symbol	Meaning	Action
	Indication	Explanation of an indication on the device.
	Warning	This symbol indicates an important tip or a dangerous situation.

Observe this instruction in order to prevent injury and damage to property.



Technical safety instructions

- This appliance complies with the applicable safety instructions. However, improper use may cause personal injury or damage to the appliance.
- Read the directions for use and the installation instructions before installing and using this appliance. You will find important information here for the assembly and use of the appliance.
- Safety is guaranteed only with expert installation in accordance with the installation manual. The installing technician is responsible for proper operation at the installation location.
- The appliance is intended exclusively for household use (preparation of food) and excludes all other domestic, commercial or industrial use. Do not use the appliance outside.
- Check the condition of the appliance and the installation fittings as soon as you remove them from the packaging. Remove the appliance from the packaging with care. Do not use sharp knives to open the packaging.
- Do not install the appliance if it is damaged, and in that case inform Novy.
- Keep good care of this manual and pass it on to any person who may use the appliance after you.
- Novy is not liable for damage resulting from incorrect assembly, incorrect connection, incorrect use or incorrect operation.
- Do not touch live components.
- Do not convert or alter the appliance.
- Remove labels and stickers on the appliance with tips for use or installation. The type sticker is to be found behind the grease filter in the appliance. Do not remove it.



Safety instructions with children in the house

- The appliance's packaging forms a hazard for children. Do not let children play with the packaging materials. Keep packaging materials away from children.
- Children from the age of 8 years and older may use this appliance only under the supervision of a person who is responsible for their safety, or if they have been taught how to use this piece of equipment under safe circumstances.
- Keep an eye on children in order to ensure that they do not play with the appliance.
- Children younger than 8 years should be kept away from the appliance and the connection cable.
- Cleaning and maintenance of the appliance may not be carried out by children.
- The appliance's lighting is extremely bright and may damage the eyes. In particular, ensure that babies do not look directly into the lights.
- Ensure that batteries are stored out of children's reach. Do not allow children to replace batteries without supervision.



Safety instructions when using the appliance

- People with restricted physical, sensory or intellectual capacities, or people lacking in knowledge or experience, may use this appliance only under the supervision of a person who is responsible for their safety, or if they have been taught how to use this piece of equipment under safe circumstances.
- Flambéing under the appliance is not allowed under any circumstances.
- Whenever you are frying, roasting, grilling or deep-frying, always stay close. Overheated oil and fat can rapidly catch alight and as a result damage the extractor hood.
- Clean the grease filter regularly in accordance with the instructions in these directions for use. Failure to follow the cleaning instructions will lead to grease deposits in the filter with a resultant fire hazard.
- Never use the appliance without the grease filters in order to prevent dirt and grease penetrating the appliance, which may impact the operation and functioning over time.
- In the event of fire, always switch the appliance off.
- Never douse burning fats with water, but cover the pan with a suitable lid or fire blanket.
- Note that certain parts of the appliance within reach of the hands may become hot while cooking.
- Gas burners can build up a lot of heat while operating. Make sure that this heat cannot increase too much in the cooker hood. The cooker hood installed above the gas burners may become damaged or catch fire.
 - Only operate the gas burners with cookware on them.
 - Turn off the gas burner when you remove the cookware from the gas.
 - When using several gas burners at the same time, set the cooker hood to position 2 or higher.
 - Never operate large burners of more than 5 kW with the highest flame for longer than 15 minutes, e.g. a wok.
- Switch on the appliance a few minutes before starting to cook for effective extraction of the cooking vapours.

- Make use of the delay position if the appliance has one. The instructions for the delay position are set out in these directions for use.
- Avoid all draughts above the cooking surface.
- Position your cooking utensils in such a way that rising vapour is directed under the extraction surface of the hood.
- Cooking with induction: set the intensity of the appliance and hob as low as possible in order to limit excess vapour.
- If the appliance has an bottom panel, ensure that it is always properly closed. Take care that it is properly inserted into the clamps and cannot come free. When opening the bottom panel, do not put your hands on the side of the hinges in order to prevent being crushed.
- Do not place objects on top of the appliance, as these may fall and cause a dangerous situation.



Air supply

However large the kitchen or the room with open kitchen is, only so much air can be extracted from the room as is supplied. Too little air supply could result in a yield loss of 50% and more.

[!] If the extraction is used at the same time as a combustion system (for example heaters fired by gas, oil, wood or coal, hot water boilers using gas, gas hobs and gas ovens), combustion gases may be sucked back in and lead to poisoning.

A combustion system uses air from the room as combustion air. Combustion gases arise as a result, which are removed to the outside by an extraction system.

The appliance sucks in air from the kitchen and adjacent rooms. Negative pressure occurs if the air supply is inadequate. The toxic gases are then sucked back from the chimney or extraction duct into the room.

With simultaneous use of the appliance and combustion appliances in the same room, the negative pressure may not exceed 4 Pa (=0.04 mBar). Negative pressure can be prevented by allowing sufficient air into the room through openings that cannot be closed (for example through windows or doors, in combination with a ventilation cabinet in the wall).

Have an expert assess the overall ventilation system in your home for a proposal on suitable measures in the area of air supply.

When using the appliance with an internal or external motor (unit) with air extraction to the outside, there must be adequate air supply in the room where the appliance has been installed / is positioned, so that fresh air can flow in. Fresh air can be provided by tilting a window, opening a door or installing an inlet grille.

With an appliance with recirculation, there must be a minimum of ventilation in the room where the appliance has been installed / is positioned. Ventilation can be provided by the overall ventilation in the home or by tilting a window or opening a door.

Certain appliances are fitted with a connection for a window contact switch (see the technical specifications for

your appliance). If the appliance is to operate at the same time as a heating appliance that needs air from the room, and if the required supply can only take place through a single open window, there is the option of connecting the appliance to a window contact switch (not included). This ensures that the appliance operates only when the window is open. If the window is closed, the fan cannot be switched on.

Contact your technician for the correct accessories for your appliance.



Precautionary measures against damage

- The correct installation method is described in the installation instructions. Read these instructions through carefully.
- The installation and electrical connection of the appliance should be left to a recognised expert.
- NOVY cannot accept liability for any damage arising from incorrect installation or connection.
- Check the distance between the hob and the appliance. The minimum and maximum heights are shown in the installation instructions.



Precautionary measures in the event of a fault

- If a fault occurs, switch off the appliance and disconnect the power supply.
- Repairs should be carried out only by specialised personnel. Do not under any circumstances open the equipment yourself. Contact the Novy service department.

ENVIRONMENTAL PROTECTION

Tips for saving energy

The new appliance is exceptionally efficient and economical with energy. Some tips follow below for making your appliance even more energy-efficient.

- Switch the appliance on at the lowest speed when you start cooking to adjust the relative humidity and eliminate cooking odours.
- Only use the highest speed when absolutely necessary.
- Only increase the speed of the appliance when the quantity of vapour so requires.
- Keep the appliance filter/filters clean to optimise grease and odour filtering efficiency.
- Switch to higher power in good time if much vapour is released. This is more efficient than using the appliance for a long time, and catching vapour already spread in the kitchen.
- Do not allow the appliance to unnecessarily ventilate after cooking.
- Switch the lighting off when leaving the kitchen or if the kitchen is already light enough.
- Ensure adequate air supply in the room, so that the appliance can operate efficiently and economically.
- Put lids on the pots to reduce cooking vapours and condensation.

Recycling the transport packaging and the old appliance

This appliance is protected against damage during transport by packaging. The materials used are not harmful to the environment and are suitable for recycling. Ensure environmentally-friendly disposal of the packaging. Your appliance also contains many materials that can be recycled.



For this reason, used appliances should be separated from other waste. Recycling of old appliances arranged by your manufacturer will in this way be carried out under the best circumstances. For recycling your appliance, we refer you to the recent European guidelines in force concerning electrical and electronic waste. Ask your municipality or your salesperson about the closest collection point for your old appliance.

Keep old appliances out of the reach of children.

Recycling batteries

Do not put batteries into the standard household refuse. Ask your municipality or your salesperson about the closest battery collection point. Keep batteries out of the reach of children.

2 CONTROLS AND FUNCTIONS

2.1 Operating the device

You can operate the cooker hood with the control buttons on the cooker hood or with the supplied remote control.

Operating on the cooker hood:

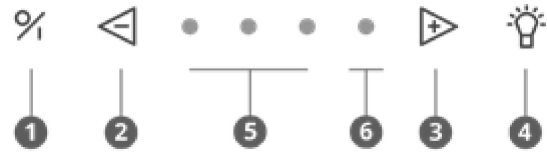

- 1 Switch on / off
- 2 Decrease speed level
- 3 Increase speed level
- 4 Lighting
- 5 Indication lights green speed 1,2,3
- 6 Indication light red Power mode

2.2 Turning the extraction on and off

Turning the extraction on off

Press button 1 to turn on the extractor. The extractor always starts in the function last used (lighting and/or motor).



Turning the extraction off with delay mode

To set delay mode press key 1 once.

The first indicator light flashes, the other indicator lights come on at the last position set. After 10 minutes the motor and lighting automatically switch off.

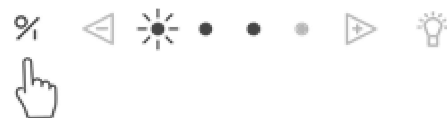

The delay time is set by default to 10 minutes in extraction mode. It is advised to always fully allow this function to work.

Switching extraction off without delay mode

Press key 1 twice.



Extractor power level

To increase the power level press key 3.



To decrease the power level press key ②.



- Three green LEDs ⑤ show positions one to three.
- The red LED ⑥ shows the Power position. The Power position is only used if there are strong odours, or a lot of smoke or vapour. Its use must be kept to a minimum because of the large extraction of air in this position.
- The Power position automatically goes back to speed three after 6 minutes.
- The motor has a thermal switch that switches the motor off with overheating. After cooling the motor will switch on again.



Determining the cause of overheating is required. This can be caused for example by a pan fire, the impeller motor being blocked or an object getting in the exhaust opening and causing it to be partly or fully blocked.

Auto-Stop

To avoid the extractor hood from staying on, the motor is automatically switched off after 3 hours (only if in 3 hours operation has not been changed). The extractor hood lighting stays on.

2.3 Lighting

Turning the lighting on and off

To turn the lighting on or off press ④.
The light works independent of the motor.



The LED lighting has a soft on/soft off mode, which means that the lighting will evenly go on and off. When switching on the lighting, this will always light up with full power and it can also be used when the fan is off.

Dimming LED lighting

When the LED lighting has been switched on, it can be dimmed by keeping key ④ pressed.

Change in colour temperature with LED-lighting

You can change the colour temperature of the LED-lighting from 2.700 K (warm white) into 4.000 K (neutral white). The description for changing this can be found in section 3.4.

2.4 Programming recirculation (optional)



If recirculation is selected programming must take place once.

This programming function activates the replacement indicator of the monobloc recirculation filter and the delay time is changed.

Activating programming

- The motor must be switched off
- Press the ② and the ③ keys at the same time for 3 seconds until the red LED flashes 5 times.



The following functions then operate:

- Replacement indicator of the monobloc filter is activated. After a set time a red indicator light on the appliance shows that the monobloc filter must be replaced.
- The delay time is set to 30 minutes (instead of the default 10 minutes).



Use the delay time of 30 minutes so the cooking odours can be properly removed in the monobloc filter.

Read paragraph 3.3 for more information about replacement of the monobloc recirculation filter.

Deactivating programming

- The motor must be switched off
- Press ② and ③ at the same time for 3 seconds until the 3rd green LED flashes 3 times.

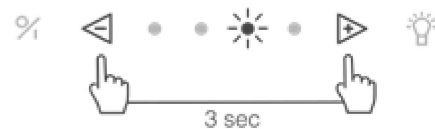

The delay time is again set to 10 minutes (instead of 30 minutes) and cleaning indicator for recirculation is switched off.

2.5 Remote control

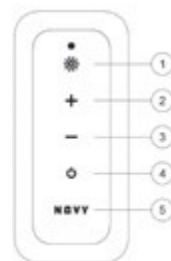



- ① Lighting
- ② Increase speed levels
- ③ Decrease speed levels
- ④ Switch on / off
- ⑤ Novy button: not applicable

The remote control for hood is preinstalled and ready for use.

Change the code on the remote control





If the set code disrupts other transmitters, another code can be selected using the remote control. There are 10 different codes.

Determine the code used

Simultaneously press  and . The lamp on the remote control flashes as many times as the selected code (there are 10 code options in total).



Change the code

- Simultaneously press and  and .
- The green light on the remote control flashes as many times as the selected code. If another code is required repeat this step again (1x flashing is code 1, 2x flashing is code 2 etc. There are total of 10 codes).
- Simultaneously press on the cookerhood  and  until the second green Speed indicator lamp is blinking.
- Press the key  on the remote control within 10 seconds to confirm the settings. The cooker hood and the remote control are now in line with each other.









2.6 InTouch

The extraction hood has the InTouch function. If you have an induction hob from Novy with InTouch, you can operate the extraction hood from the hob. There is also the option that the extraction hood can be operated with a remote control.

Programming InTouch on the induction plate

The remote control must first work with the hood. If necessary, the remote control code can be changed, as described in Section 2.5

- Connect the plate to the mains supply.
- Touch simultaneously the keys  and  on the induction plate until you hear a beep signal (prox. 7 sec.).
- The cooker plate now searches automatically for the hood code.
- Wait until the cooker hood illumination begins to flashing OR you hear a "click" sound when you have an extractor hood without lighting (Be patient, this can betake a while).
- Does the light blink or you hear the "click" sound; press immediately on any InTouch key or  or  or  or  on the induction hob.
- You will hear a "beep" signal to indicate the link between the two devices.



Now you can operate the hood with the keys on the induction plate.

You can find more information about using the InTouch functions in the InTouch manual for the hob or remote control.



Turning the InTouch function on and off



The InTouch function is on by default. Turning off the InTouch function on the cooker hood results in the connection between cooker hood and Novy induction hob with InTouch and/ or remote control is also disabled.

To switch the InTouch function off press the  and  keys at the same time for 3 seconds and the 2nd and 4th LEDs flash 3 times to confirm. (The appliance must be switched off).



The function can be switched on by pressing the  and  keys at the same time for 3 seconds.

The 2nd and 3rd LEDs flash 3 times to confirm (the appliance must be switched off).



3 CLEANING AND MAINTENANCE



Follow all instructions as described in the Conditions for Safety and Use section.



Follow the cleaning instructions below for a longer working life and optimal operation of the appliance.



The bottom panel, grease filter and recirculation filter can fall out when you are handling them. This can result in damage. Make sure you hold the bottom panel and the filter(s) securely at all times when handling them.



WARNING! Risk of injury! Open and close the bottom panel slowly. Use a stable stepladder and pay attention to stability. Do not step on the hob or the worktop surface.

3.1 General maintenance



Allow the lighting to cool down sufficiently before you start cleaning the extractor hood.



Never use aggressive, abrasive or chlorinated products.



Do not use a high pressure or steam cleaner.

Stainless steel

Clean with a cleansing tissue with mild cleaning agent then dry with a soft cloth. Maintenance of the stainless steel can be performed with the Novy cleaner (906060).

Coated parts of the extractor hood

The extractor hood can be cleaned with a damp cleansing tissue and a mild cleaning agent.

Glass

Glass parts of the extractor hood can be cleaned with a soft cloth and a glass cleaner.

3.2 Removing the bottom panel

If the bottom panel is to be removed from the cooker hood for cleaning, proceed as follows:

- Grasp the bottom panel at the left and right ends.
- Slowly tilt the bottom panel downwards and continue to hold it in place.
- As soon as the bottom panel is at a 90° angle downwards, the bottom panel can be slid to the right to remove it from the hinges. Here you will feel some resistance. Do this with caution to prevent damage to the cooker hood. Make sure you hold the bottom panel securely at all times.
- The bottom panel can then be cleaned by hand. The bottom panel is not suitable for cleaning in the dishwasher.
- Before reinstalling the bottom panel, immediately clean the accessible parts on the inside of the cooker hood.
- To replace the bottom panel, grasp the bottom panel at the left and right ends and hold it in place. Make sure you hold the bottom panel securely at all times.
- Hold the bottom panel in a 90° angle downwards and slide the bottom panel to the left over the hinges until you notice a click.
- The bottom panel cannot be closed if the bottom panel is not fully positioned over the hinges.
- The bottom panel can then be closed.

3.3 Grease filter



If the following instructions are not carried out, serious soiling can cause a fire hazard.

Indication cleaning grease filter



Indication: 4 flashing indicator lights



After 20 cooking hours 4 flashing indicator LEDs show that the grease filter must be cleaned.

Reset the cleaning indicator



When you replace the grease filter after cleaning, it is sufficient to press the **2** key for 5 seconds to again set the indicator.

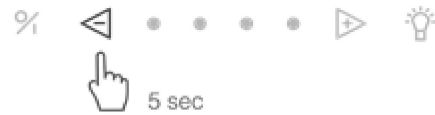

If you do not do this the indicator light will continue to flash when switching on the extractor hood.

Accessing the grease filter

Take hold of the right and left side of the bottom panel (A) and pull down simultaneously. Remove the filter (B) by taking hold of its hook and pulling down.

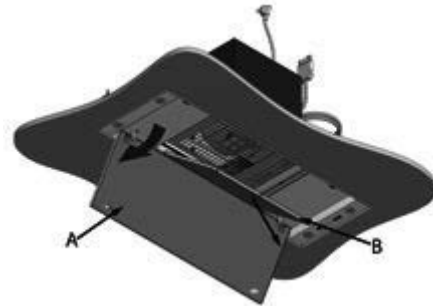

Cleaning the grease filter

The metal grease filter can be cleaned by hand or in a dishwasher. We recommend cleaning the grease filter by hand.

Cleaning the filter by hand:

- Immerse the filter in a solution of boiling water to which a degreasing detergent has been added.
- Use a brush for cleaning
- Then rinse the filters with warm water under a tap and allow them to dry.

Cleaning the filter in a dishwasher:

- Use a customary dishwasher detergent
- Do not put the saturated grease filters together with crockery in the dishwasher
- Select a programme with a low temperature
- After cleaning allow the filter to drain.



When cleaning in a dishwasher the filter may discolour as a result of the salt content. This does not affect its operation.

Replacing the grease filters

- Before replacing the grease filter, clean the edges of the part in the extractor hood in which the filter is placed.
- Grasp the filter with 2 hands.
- Make sure that the lock or the lip on the filter is on the bottom side.
- Insert the back of the filter in the opening, press the filter upwards at the front and make sure it clicks tight.



You can obtain a new grease filter from a dealer or the Novy website. Article number grease filter: 810/811/816: 609.014
820/821/826: 7400.020

3.4 Monoblock recirculation filter (optional)

When selecting recirculation, always set the recirculation programme on the extractor hood (see paragraph 2.4)

If recirculation is chosen the appliance is connected to an outlet box with a monobloc recirculation filter, or a monobloc recirculation filter is fitted in the extractor hood behind the grease filter.

Replacement indicator monobloc recirculation filter



Indication: red indicator light stays on



After a set time a red indicator light on the appliance shows that the monobloc filter must be replaced.

Reset the replacement indicator



After replacing the monobloc filter(s), carry out the following action. The motor of the cooker hood must be running. Simultaneously press 2 and 3 for 3 seconds until the red indicator led flashes 3 times for confirmation. If the cooker hood is not reset, it will automatically reset after the motor of the cooker hood has been switched on 10 times.



Installing the monoblock filter

Refer to your recirculation kit manual for removal and installation of the monoblock filter.



You can obtain a new monobloc filter from a dealer or the Novy website.

3.5 Led lighting

Replacing the led lighting

First, remove the power supply from the hood and allow the lighting to cool down sufficiently.



The spotlight holders can easily slip out of your hands. This can cause damage. Therefore, hold the spotlight holders firmly when removing and reinserting them.

1. Open the bottom panel of the cooker hood. Press the spotlight holder carefully, and then use a tilting movement to remove the spotlight holder from the cooker hood. Do this with two hands.

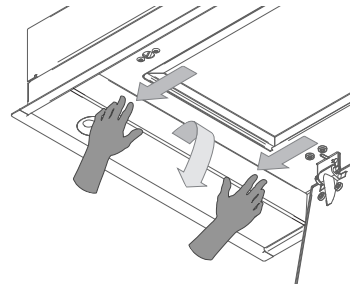

2. Removing the LED spotlight:
 - A. First disconnect the cable leading to the LED spotlight to be replaced. Disconnecting is done by releasing the lock by applying a light pressure and pulling it off at the same time.
 - B. Then remove the LED spotlight to be replaced by making a soft rotating movement counterclockwise.
 - C. Remove the LED spotlight to be replaced from the bayonet ring.

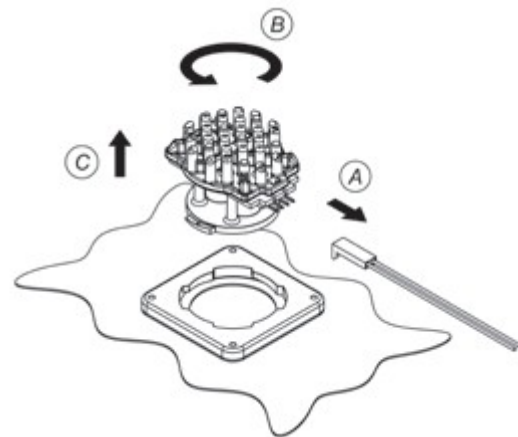

3. Mounting the new LED:
 - A. Place the new LED light into the locking ring.
 - B. Make a rotating movement to the right until the LED light is locked.
 - C. Connect the power cable.



Colour LED lighting 2,700K (warm white) or 4,000K (neutral white) depending on choice of connection. Make sure that all LED spots are connected in the same way to prevent a difference in colour of LED lighting.

- D. Place the spotlight holder back in the cooker hood and reconnect the power.

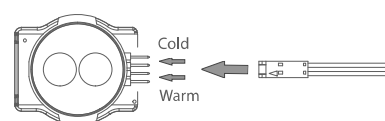

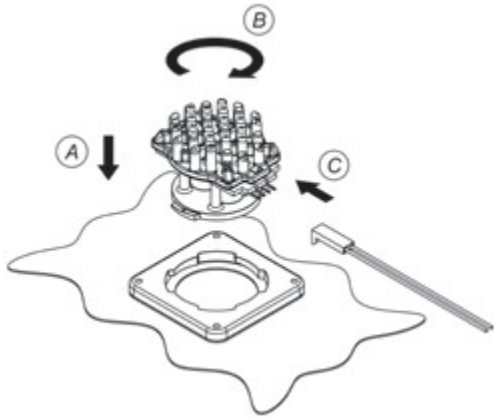

Change in colour temperature with LED-lighting

First make sure that the power supply of the hood has been disconnected. Remove the plug from the hood or switch off the power group.

The colour of the LED-lighting has been set to 2.700 K (warm white) by default. If the colour is to be changed to 4.000 K (neutral white), follow the instruction given below:



The spotlight holders can easily slip out of your hands. This can cause damage. Therefore, hold the spotlight holders firmly when removing and reinserting them.

- Open the bottom panel at the bottom of the hood.
- Open the bottom panel of the cooker hood. Press the spotlight holder carefully, and then use a tilting movement to remove the spotlight holder from the cooker hood. Do this with two hands.

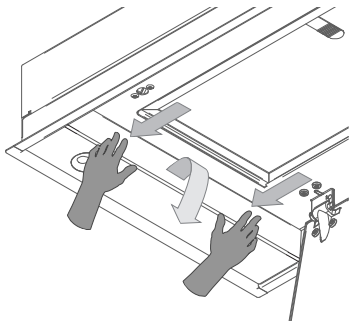

- The wiring has been connected to the LED-lamp with a connector.
- Disconnect the connector from the LED-lamp and move the wiring to the other free connection on the lamp.



Colour LED lighting 2,700K (warm white) or 4,000K (neutral white) depending on choice of connection. Make sure that all LED spots are connected in the same way to prevent a difference in colour of LED lighting.

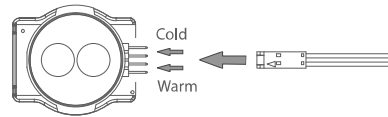

- Repeat this for all four LED-lamps.
- Then close the inox lamp holder again.

The colour of the LED-lighting has now been changed from 2.700 K to 4.000 K.

3.6 Change the batteries

- For changing the batteries unscrew the plastic cover, remove the old batteries and insert the new ones. Pay attention to the polarity marking given in the battery compartment.
- Empty batteries are not to be disposed of in the household refuse, but they are to be handed in as chemical waste.



Technical information

- Power supply: 2xAAA batteries
- Frequency: 433.92Mhz
- Numbre of codes: 10
- Worktemperature: 0-50°C
- Dimensions: 110 x 50 x 19mm

3.7 Faults

If there is a fault you can contact your (kitchen) supplier and/or Novy Customer Service.

Belgium Tel.: +32 (0)56 36 51 02
 France Tel.: +33 (0)3 20 94 06 62
 Germany Tel.: +49 (0)511 54 20 771
 The Netherlands Tel.: +31 (0)88 011 91 10
 United Kingdom Tel.: +44 (0) 207 866 2493
 Italy Tel.: +39 (0)39.20.57.501

For all other countries: your local installer or Novy in Belgium: +32 (0)56 36 51 02

To be able to deal with the fault promptly and efficiently it is necessary that the Repaired Service knows which type of appliance you have.



You can find the type number on a sticker in the inside of the extractor hood. This becomes visible as soon as you take the filter out of the extractor hood.

You can note the type number here:

4 QUICKGUIDE

4.1 Settings

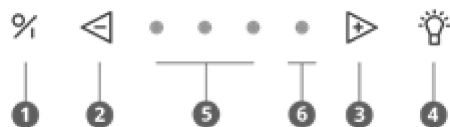

EXPOSED	ACTION	INDICATION	NOTE	PAG.
Switching on the engine	1			p 35
Switching off the motor with delay mode	1	Green LED flashes	Engine stays on for 10 minutes	p 35
Switching off the motor without delay mode	2 x 1		Engine goes off immediately	p 35
Increase engine speed	3			p 35
Decrease engine speed	2			p 36
Lighting on	4			p 36
Dimming the lighting	Continue to press 4			p 36
Recirculation on	2 + 3 for 3 seconds	Red LED flashes 5x	! Motor must be switched off !	p 36
Recirculation off	2 + 3 for 3 seconds	Third green LED flashes 5x	! Motor must be switched on !	p 36
Reset cleaning indicator grease filters	2 for 5 seconds.			p 38
Reset replacement indicator monoblock	2 + 3 for 3 seconds	Red LED flashes 3x	! Motor must be switched on !	p 39
InTouch on	1 + 3 for 3 seconds	2nd en 3th LED flashes	! Motor must be switched off !	p 37
InTouch off	1 + 2 for 3 seconds	2nd en 4th LED flashes	! Motor must be switched off !	p 37

4.2 Indications

INDICATION	EXPOSED	NOTE	PAGE
Four flashing LEDs	Grease filter must be cleaned	If the cleaning instructions are not followed, excessive contamination, risk of fire and loss of efficiency will result.	p 38
Red indication LED lights up	Time to replace the monobloc recirculation filter used		p 39

GARANTIEVOORWAARDEN - LES CONDITIONS DE GARANTIE - DIE GARANTIEBEDINGUNGEN - WARRENTY CONDITIONS

BELGIË

Novy damkappen worden met de grootst mogelijke zorgvuldigheid geproduceerd. Desalniettemin kan er een defect optreden. Zowel binnen als buiten de waarborgperiode, kan de Novy technische dienst op een snelle en deskundige manier een herstelling van het toestel uitvoeren, zonder dat dit afbreuk doet aan de levensduur ervan.

Aanvang en duur van de waarborgperiode

De waarborgperiode vangt aan op de datum van aflevering door de verkoper (factuurdatum als bewijs) van het toestel bij de consument. De duur ervan bedraagt 60 maanden, maar wordt beperkt tot 12 maanden ingeval van industrieel of hiermee gelijkgesteld gebruik, bv. in hotels, pensions, ...

Beperkingen

Deze waarborg is niet geldig wanneer het gaat om fouten, veroorzaakt door normale sleet, misbruik of verwaarlozing, of door ondeskundige plaatsing. Anderzijds vervalt de waarborg wanneer het apparaat zou hersteld of omgebouwd zijn met onderdelen die niet van ons fabrikaat zijn of wanneer de identificatienummers zouden zijn verwijderd of veranderd.

Er is evenmin sprake van waarborg wanneer het apparaat zou hersteld of veranderd zijn door personen die niet door onze firma daartoe gemachtigd zijn. De volledige lijst met beperkingen is beschikbaar op aanvraag.

De waarborgvoorwaarden gelden voor in België op de markt gebrachte en in gebruik zijnde toestellen. Bij ingebruikname in het buitenland van een in België gekocht toestel, of in België van een in het buitenland gekocht toestel moet de consument er zich van vergewissen of het toestel voldoet aan de lokale technische vereisten (gassoort, spanning, frequentie, installatievoorschriften, klimaatomstandigheden). Schade veroorzaakt door het niet geschikt zijn van het toestel en de noodzakelijke of gewenste aanpassingen vallen niet onder de waarborgvoorwaarden.

Aanvraag tot herstelling

Wanneer een onderdeel defect bevonden wordt, dient het via de vakhandelaar of keukeninstallateur te worden teruggestuurd aan ons adres, ontstaan van alle andere onderdelen en verzegeld van een aanvraag tot vervanging onder waarborg door afzender alsmede van dit certificaat en factuur. Tel. nr Technische Dienst NOVY (te contacteren bij defect): 056-36 51 02 Hou dit document steeds bij de hand

BELGIQUE

Les hottes Novy sont toujours fabriquées avec le plus grand soin possible. Cela n'exclut pas l'éventualité d'un défaut. Le service technique de Novy peut réparer votre appareil rapidement et correctement, aussi bien durant la période de garantie, qu'après, sans porter préjudice à sa durée de vie.

Début et durée de la période de garantie

La période de garantie débute à la date de livraison par le vendeur au domicile du client (la date de la facture fait foi). La durée est 60 mois, limitée à 12 mois pour une utilisation industrielle ou comparable, dans les hôtels, pensions, ...

Limitations

Cette garantie n'est pas valide quand il s'agit de défauts suite à l'usure normale, une utilisation non conforme ou négligence ou à une installation non conforme. D'autre part, la garantie est annulée si l'appareil a été réparé ou modifié avec des pièces qui ne sont pas d'origine, ou lorsque les numéros d'identification ont été démontés ou modifiés.

La garantie ne sera pas non plus applicable quand l'appareil a été réparé ou modifié par une personne non autorisée par notre entreprise.

La liste complète des limitations est disponible sur demande.

Les conditions de garantie sont valides pour les appareils commercialisés et utilisés en Belgique. Lorsque l'appareil acheté en Belgique est utilisé à l'étranger ou un appareil acheté à l'étranger est utilisé en Belgique, il incombe au consommateur de vérifier si l'appareil correspond aux exigences techniques locales (type de gaz, tension, fréquence, conditions d'installation, conditions climatiques). Les dégâts occasionnés par une utilisation non conforme ou adéquate et les adaptations nécessaires ou souhaités ne sont pas concernés par les conditions de la garantie.

Demande de réparation

En cas de pièce défectueuse, il convient de vous adresser au commerçant spécialisé ou installateur de cuisine qui la renverra à l'usine, accompagné de

votre demande de remplacement sous garantie, du certificat de garantie et de votre facture.

Tél. No du service technique de NOVY (à contacter en cas d'un défaut): 056-36 51 02

Gardez ce document toujours à portée de main.

BELGIEN

Dunstabzugshauben von Novy werden mit größtmöglicher Sorgfalt hergestellt. Dennoch kann es zu einem Defekt kommen. Sowohl während der Garantiefrist als auch darüber hinaus kann der technische Dienst von Novy das Gerät schnell und fachkundig reparieren, ohne dass dies die Lebensdauer des Gerätes beeinträchtigt.

Beginn und Dauer der Garantiefrist

Die Garantiefrist beginnt an dem Tag, an dem der Verkäufer (Rechnungsdatum gilt als Beleg) das Gerät an den Verbraucher liefert. Die Garantiefrist beträgt 60 Monate, wird jedoch bei industrieller oder vergleichbarer Nutzung z. B. in Hotels, Pensionen, ... auf 12 Monate verkürzt.

Einschränkungen

Diese Garantiefrist hat keine Gültigkeit, wenn es um Fehler geht, die auf normalen Verschleiß, Missbrauch bzw. mangelnde Pflege oder nicht sachkundige Aufstellung zurückzuführen sind. Andererseits erlischt der Garantieanspruch, wenn das Gerät mit Teilen repariert oder umgebaut wird, die nicht von unserem Hersteller stammen, oder wenn die Gerätekennummern entfernt oder verändert werden. Ein Garantieanspruch liegt ebenso wenig vor, wenn das Gerät von Personen repariert oder verändert wird, die nicht die entsprechende Zulassung unserer Firma besitzen.

Die vollständige Liste der Einschränkungen erhalten Sie auf Anfrage.

Die Garantiebedingungen gelten für in Belgien auf den Markt gebrachte und verwendete Geräte. Bei Inbetriebnahme eines in Belgien erworbenen Gerätes im Ausland oder eines im Ausland erworbenen Gerätes in Belgien hat sich der Verbraucher zu vergewissern, ob das Gerät den lokalen technischen Anforderungen (Gasqualität, Spannung, Frequenz, Installationsvorschriften, Klimabedingungen) gerecht wird. Schäden, die auf die Tatsache zurückzuführen sind, dass das Gerät für den gewünschten Verwendungszweck nicht geeignet ist und die notwendigen oder gewünschten Änderungen unangemessen sind, fallen nicht unter die Garantiebedingungen.

Reparaturanfrage

Wird ein Defekt an einem Ersatzteil festgestellt, ist es über den Fachhändler oder den Küchenbauer an unsere Adresse zurückzuschicken, und zwar vollständig ausgebaut und versehen mit einer Anfrage des Absenders zum Austausch im Rahmen des Garantieanspruchs sowie dieses Zertifikats und der Rechnung.

Telefonnummer Technischer Dienst NOVY (bei einem Defekt): +32-(0)56-36 51 02.

Bewahren Sie dieses Dokument immer griffbereit auf.

FRANCE

Les hottes Novy sont toujours fabriquées avec le plus grand soin possible. Cela n'exclut pas l'éventualité d'un défaut. Le service technique de Novy peut réparer votre appareil rapidement et correctement, aussi bien durant la période de garantie, qu'après, sans porter préjudice à sa durée de vie.

Début et durée de la période de garantie

La période de garantie débute à la date de livraison par le vendeur au domicile du client (la date de la facture fait foi). La durée est 60 mois, limitée à 12 mois pour une utilisation industrielle ou comparable, dans les hôtels, pensions, ...

Limitations

Cette garantie n'est pas valide quand il s'agit de défauts suite à l'usure normale, une utilisation non conforme ou négligence ou à une installation non conforme. D'autre part, la garantie est annulée si l'appareil a été réparé ou modifié avec des pièces qui ne sont pas d'origine, ou lorsque les numéros d'identification ont été démontés ou modifiés.

La garantie ne sera pas non plus applicable quand l'appareil a été réparé ou modifié par une personne non autorisée par notre entreprise.

La liste complète des limitations est disponible sur demande.

Les conditions de garantie sont valides pour les appareils commercialisés et utilisés en France. Lorsque l'appareil acheté en France est utilisé à l'étranger ou un appareil acheté à l'étranger est utilisé en France, il incombe au consommateur de vérifier si l'appareil correspond aux exigences techniques locales (type de gaz, tension, fréquence, conditions

d'installation, conditions climatiques). Les dégâts occasionnés par une utilisation non conforme ou adéquate et les adaptations nécessaires ou souhaités ne sont pas concernés par les conditions de la garantie.

Demande de réparation

En cas de pièce défectueuse, il convient de vous adresser à votre revendeur ou installateur de cuisine qui la renverra à l'usine, accompagné de votre demande de remplacement sous garantie, du certificat de garantie et de votre facture.

DEUTSCHLAND und ÖSTERREICH

Dunstabzugshauben von Novy werden mit größtmöglicher Sorgfalt hergestellt. Dennoch kann es zu einem Defekt kommen. Sowohl während der Garantiefrist als auch darüber hinaus kann der technische Dienst von Novy das Gerät schnell und fachkundig reparieren, ohne dass dies die Lebensdauer des Gerätes beeinträchtigt.

Beginn und Dauer der Garantiefrist Die Garantiefrist beginnt an dem Tag, an dem der Verkäufer (Rechnungsdatum gilt als Beleg) das Gerät an den Verbraucher liefert. Die Garantiefrist beträgt vierundzwanzig Monate.

Einschränkungen

Diese Garantiefrist hat keine Gültigkeit, wenn es um Fehler geht, die auf normalen Verschleiß, Missbrauch bzw. mangelnde Pflege oder nicht sachkundige Aufstellung zurückzuführen sind. Andererseits erlischt der Garantieanspruch, wenn das Gerät mit Teilen repariert oder umgebaut wird, die nicht von unserem Hersteller stammen, oder wenn die Gerätekennummern entfernt oder verändert werden. Ein Garantieanspruch liegt ebenso wenig vor, wenn das Gerät von Personen repariert oder verändert wird, die nicht die entsprechende Zulassung unserer Firma besitzen.

Die vollständige Liste der Einschränkungen erhalten Sie auf Anfrage.

Die Garantiebedingungen gelten für in Belgien auf den Markt gebrachte und verwendete Geräte. Bei Inbetriebnahme eines in Belgien erworbenen Gerätes im Ausland oder eines im Ausland erworbenen Gerätes in Belgien hat sich der Verbraucher zu vergewissern, ob das Gerät den lokalen technischen Anforderungen (Gasqualität, Spannung, Frequenz, Installationsvorschriften, Klimabedingungen) gerecht wird. Schäden, die auf die Tatsache zurückzuführen sind, dass das Gerät für den gewünschten Verwendungszweck nicht geeignet ist und die notwendigen oder gewünschten Änderungen unangemessen sind, fallen nicht unter die Garantiebedingungen.

Reparaturanfrage

Wird ein Defekt an einem Ersatzteil festgestellt, ist es über den Fachhändler oder den Küchenbauer an unsere Adresse zurückzuschicken, und zwar vollständig ausgebaut und versehen mit einer Anfrage des Absenders zum Austausch im Rahmen des Garantieanspruchs sowie dieses Zertifikats und der Rechnung. Bewahren Sie dieses Dokument immer griffbereit auf.

NOVY NEDERLAND B.V.

Garantietermijn en dekking

Een storing is een openbaring van een technisch gebrek aan het huishoudelijk apparaat, ten gevolge van een materiaal-, ontwerp- en/of productiefout, waardoor het normaal functioneren van het apparaat onmogelijk is. Met inachtneming van de onderstaande voorwaarden, wordt door Novy Nederland B.V. 5 jaar garantie verleend. De garantie gaat in op de datum van aankoop zoals die vermeld staat op de aankoopnota van de desbetreffende keukendetaillist/installateur. In het 1e en 2e jaar krijgt u bij optredende storing aan uw Novy-apparaat volledige garantie op materiaal, voorrijkosten en arbeidsloon. Bij storingen die optreden in het 3e, 4e of 5e jaar geeft deze garantie recht op vergoeding van de te vervangen onderdelen. Bij een servicebezoek in het 3e, 4e of 5e jaar worden alleen de op dat moment geldende voorrijkosten en arbeidsloon in rekening gebracht. Bij de openbaring van een storing binnen 6 maanden na aflevering, wordt vermoed dat de storing reeds bij aflevering aanwezig was. Servicebezoeken worden uitsluitend op werkdagen tussen 8:00 en 17:00 uur uitgevoerd en vinden uitsluitend in Nederland plaats. Deze garantie van het huishoudelijke apparaat geldt niet bij een toepassing in een niet-huishoudelijke situatie. De garantie is overdraagbaar op eigenaar en/of adres.

Beperkingen

De garantie heeft geen betrekking op onderdelen zoals lampen, glasplaten, veltfilters, geurfilters, snoer, steker en losse accessoires. Op de garantie kan geen aanspraak worden gemaakt bij gebreken

aan het apparaat die terug te voeren zijn op onjuist gebruik, ondeugdelijk onderhoud, onachtzaamheid, het niet juist handelen volgens de bepalingen in de gebruiksaanwijzing of de montage-instructie, gebreken die te wijten zijn aan installatiefouten of gebreken die de werking of de waarde van het apparaat niet noemenswaardig beïnvloeden. Eveneens kan er geen aanspraak op de garantie worden gedaan bij beschadigingen die ontstaan zijn door de gebruiker of derden, defecten en beschadigingen van het apparaat als gevolg van gebeurtenissen die gewoonlijk verzekerd zijn onder een inboedelverzekering of gebeurtenissen die buiten het normale gebruik van het apparaat vallen.

Bij een apparaat die ingebouwd is geweest in de showroom van een (keuken)leverancier wordt de garantie beperkt tot de technische delen. Beschadigingen van zichtbare delen zijn uitgesloten van garantie.

Voorwaarden

Een aanspraak op de garantie vervalt indien reparaties of ingrepen worden uitgevoerd door derden die niet door Novy gemachtigd zijn, of indien apparaten worden voorzien van niet-originele onderdelen waardoor een storing ontstaat. De reparaties aan de producten worden in de regel bij de eindgebruiker uitgevoerd. De onderdelen die zijn vervangen, worden eigendom van Novy. Bij een reparatie dient te allen tijde de originele aankoopnota aan de servicemonteur te worden overlegd.

De reparatie zal zoveel mogelijk tijdens het eerste bezoek worden uitgevoerd. Indien een tweede bezoek nodig is, zullen eventueel voorrijkosten en arbeidsloon in rekening worden gebracht, indien de noodzaak voor een herhaalbezoek aan de eindgebruiker toe te schrijven is.

Garantiegevallen leiden niet tot een verlenging van de garantietermijn en vormen evenmin het begin van een nieuwe garantietermijn. De garantietermijn voor ingebouwde vervangingsonderdelen eindigt gelijktijdig met de garantietermijn van het apparaat als geheel.

Indien het typeplaatje met daarop het typenummer en serienummer is verwijderd, gewijzigd of onleesbaar is, vervalt elke aanspraak op de garantie.

De garantievoorwaarden gelden voor in Nederland op de markt gebrachte en in gebruik zijnde apparaten. Bij ingebruikname in het buitenland van een in Nederland gekocht apparaat, of in Nederland van een in het buitenland gekocht apparaat moet de consument zich van bewust zijn of het apparaat aan de lokale technische vereisten (bijvoorbeeld spanning, frequentie, installatievoorschriften, klimaatomstandigheden). Schade veroorzaakt door het niet geschikt zijn van het apparaat en de noodzakelijke of gewenste aanpassingen vallen niet onder de garantievoorwaarden.

Uitgebreidere of andere aanspraken, in het bijzonder aanspraken op vergoeding van buiten het apparaat ontstane schade, zijn uitgesloten, voor zover de aansprakelijkheid niet voortvloeit uit wettelijke bepalingen van dwingend recht.

Indien bij aanmelding van een storing de omschrijving van de storing niet leidt tot een vaststelling van deze storing door de servicemonteur en bovendien een verder inspectie van het apparaat ook geen vaststelling van een mogelijk ander defect oplevert, zullen voorrijkosten en arbeidsloon in rekening worden gebracht overeenkomstig op dat moment geldende tarieven.

Reparatie en eventuele vervanging van een apparaat Voor zover herstellwerkzaamheden door Novy Nederland B.V. redelijkerwijs niet mogelijk zijn, wordt op verzoek van de eindgebruiker binnen de genoemde garantietermijn een gelijkwaardige vervangend apparaat aangeboden. Bij een levering van een vervangend apparaat behoudt Novy Nederland B.V. zich het recht voor een redelijke gebruiksvergoeding in rekening te brengen voor de tot dan toe genoten gebruiksduur.

Aanvraag voor een service

In geval van een storing kunt u contact opnemen met uw (keuken)leverancier. Voor een goede en snelle afhandeling is het noodzakelijk dat u bij het melden van een service het type nummer van uw apparaat bij de hand heeft.

Onderdelen bestellen

Voor het bestellen van onderdelen kunt u zich wenden tot:

Novy Nederland B.V.
T (088)-0119100
E info@novynederland.nl
I www.novynederland.nl

NOVY nv behoudt zich het recht voor te allen tijde en zonder voorbehoud de constructie en de prijzen van haar producten te wijzigen.
NOVY SA se réserve le droit de modifier à tout moment et sans réserve la fabrication et les prix de ses produits.
Die NOVY AG behält sich das Recht vor, zu jeder Zeit und ohne Vorbehalt die Konstruktion und die Preise ihrer Produkte zu ändern.
NOVY nv reserves the right at any time and without reservation to change the structure and the prices of its products.

NOVY

NOVY nv
Noordlaan 6
B - 8520 KUURNE
Tel. 056/36.51.00
Fax 056/35.32.51

E-mail: novy@novy.be
www.novy.com

France: Tél: 0320.940662
Deutschland und Österreich: Tel: +49 (0)511.54.20.771
Nederland: Tel.: +31 (0)88-0119110
United Kingdom: +44 (0)207 866 2493
España: Tel.: +34 938 700 895
Italia: Tel.: +39 039.20.57.501